

CONTENTS	2
GENERAL INFORMATION	2
SAFETY INSTRUCTIONS	4
OPERATOR UNIT	5
OPERATOR INSTALLATION	6
ELECTRICAL CONNECTIONS	8
MANUAL OPENING	14
MAINTENANCE	15
TROUBLESHOOTING	15
APPENDIX	16

# OPERATOR

**SECTIONAL-500PROCE/750PROCE/1000PROCE**



Installation and Operating Manual

**CONTENTS**

1. GENERAL INFORMATION . . . . . 2  
 1.1. Specifications . . . . . 3  
 1.2. Operator package. . . . . 3  
 1.3. Track . . . . . 3  
 2. SAFETY INSTRUCTIONS . . . . . 4  
 3. OPERATOR UNIT . . . . . 5  
 4. OPERATOR INSTALLATION . . . . . 6  
 4.1. Tools . . . . . 6  
 4.2. Requirments to door installation . . . . . 6  
 4.3. Connection of operator and guide . . . . . 6  
 4.4. Track installation . . . . . 7  
 5. ELECTRICAL CONNECTIONS . . . . . 8  
 5.1. Control block specifications . . . . . 8  
 5.2. Control block wiring diagram . . . . . 8  
 5.3. Operator programming . . . . . 9  
 5.4. Remote control programming . . . . . 12  
 6. MANUAL OPENING . . . . . 14  
 7. MAINTENANCE . . . . . 15  
 8. TROUBLESHOOTING . . . . . 15  
 APPENDIX . . . . . 16

**1. GENERAL INFORMATION**

Electromechanical drive chain type Sectional-500PROCE/750PROCE/1000PROCE is designed to automate everyday balanced sectional doors.

It consists of a mechanical gear and an electric engine with a built-in control unit. The gear and the electric engine are incorporated into a housing.

It consists of an electromechanical motor reducer, an electronic control unit and an illuminating lamp, incorporated into a housing. The electric operator is easily secured on a track and mounted to the ceiling, opening of the doors is carried out by means of a chain/belt gear. The self-locking operator gear ensures mechanical interlocking of the doors, if engine is not functioning, but in the absence of electric power the manual emergency release allows you to open and to close the doors manually.

For maximum safety, the control unit has force protection.

Besides, optionally, the operator can be equipped by electronic protective sensors, which stop the doors closing, if there are obstacles or people within the operating range of automatic system.

**1.1. SPECIFICATIONS**

Parameters	SE 500PRO CE	SE 750PRO CE	SE 1000PRO CE
Power supply	220–240 V		
Consumed power	150 W	150 W	250 W
Waiting mode	6 W	6 W	10 W
Force	500 N	750 N	1000 N
Control	Stepped (pulse) mode		
Motor	24B DC		
Opening speed	0,1 m/sec		
Door area DoorHan	til 8m <sup>2</sup>	til 10m <sup>2</sup>	till 13,5 m <sup>2</sup>
Operating temperatures range	–20...+55 °C		
Fuses	Power supply — 2.5 A		
Radio control	433,92 MHz (max 60 remote control)*		
Transmission	Chain/Belt		
Protection rating	IP 20		







\* - may increase with the installation of external radio receiver.

**! WARNING!** If there are wicket, glass or non standard parts it is recommended to provide reserve till 20% of maximal DoorHan sectional doors square.

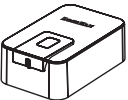
**1.2. OPERATOR PACKAGE**

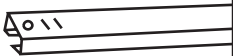
When you receive your Sectional-500PROCE/750PROCE/1000PROCE operator, unpack it and check that the operator is not damaged. If any damages are found, contact the operator supplier.

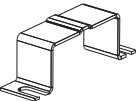
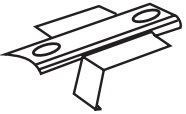
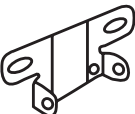
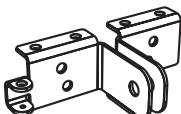
The operator components included in the standard package are listed in the following table.

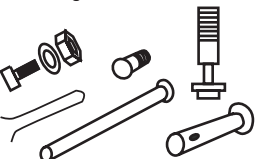
<b>Electric operator</b> 	<b>Operating manual</b> 	<b>Guide</b> 	<b>Curved arm</b> 	<b>U-shaped bracket</b> 
<b>Guide fastening bracket</b> 	<b>Headroom bracket</b> 	<b>Straight arm fastening bracket</b> 	<b>Slotted bushing</b> 	<b>Fastening set</b> 

N <sub>e</sub>	Name	Quantity	N <sub>e</sub>	Name	Quantity
1	Electric operator	1	6	Guide fastening bracket	1
2	Operating manual	1	7	Headroom bracket	1
3	Guide	1	8	Straight arm fastening bracket	1
4	Curved arm	1	9	Slotted bushing	1
5	U-shaped bracket	2	10	Fastening set	1

**1.3. TRACK**

Guide model	Guide length, L	Travel	Opening height
SK-3300 chain/PK-3300 belt	3 320 mm	3 100 mm	≤ 2 500 mm
SK-3600 chain/ PK-3600 belt	3 620 mm	3 400 mm	≤ 2 800 mm
SK-4200 chain/ PK-4200 belt	4 220 mm	4 000 mm	≤ 3 400 mm
SK-4600 chain/ PK-4600 belt	4 620 mm	4 400 mm	≤ 3 800 mm

## 2. SAFETY INSTRUCTIONS



**IMPORTANT!** You should observe the safety regulations to preserve people's health. You must keep the present Manual.

- You should follow all the recommendations of the given Manual, as incorrect equipment installation could lead to serious damages.
- The Sectional-500PROCE/750PROCE/1000PROCE operator is designed for automation of residential sectional doors. It should be used only for the purpose intended; any other use is forbidden.
- DoorHan is not liable for personal injuries, if the product was used for purposes other than intended.
- Make sure that the doors are balanced and function smoothly before installing the operator.
- The installation is to be carried out according to the standards EN 12453 and EN 12445. For providing the required safety level, these requirements should be observed in non-EU countries.
- You should check if the doors conform to the standards EN 12604 and EN 12605 (see documentation on the doors). For non-EU countries these measures are to be observed for ensuring the normal safety level.
- The mechanical door assembly units must conform to the provisions of the standards EN 12604 and EN 12605.
- The gate must manually move smoothly all the way, with a force of more than 20 kg.
- Before installing the operator, make sure that the mounting location by its climatic conditions corresponds to the operator's specifications.
- You should not install the equipment in rooms with highly flammable substances or other hazardous media, as this can result in explosion or fire.
- You should use tools, indicated in Section "Tools" of the given Manual, during assembly, installation and adjustment of the operator.
- You should use a stable support when working at height.
- The operator is allowed to install at more than 2.5 m height.
- You should use hand and face protection when drilling holes.
- You should use metal goods from the operator package or other goods equivalent to them for fastening the product.
- You should power off when performing installation, cleaning or maintenance of the operator.
- When mounting the operator on doors with the infitting pass door, it is necessary to install an additional safety device, which prevents the operator activation, when the door is open.
- Make sure, that there will not be trapping of articles between movable and fixed elements of the operator when the doors move.
- You should use additional DoorHan accessories, since the accessories of third party manufacturers can damage the automatic system.
- DoorHan is not liable for unstable work of the automatic system, if you use safety devices and accessories, produced by other manufacturers without securing approval of DoorHan.
- You should not leave electric engines in a released state. This can lead to uncontrolled movement of the door wings and, as a result, to their damage.
- You should not use the operator, if it is necessary to repair or to adjust the equipment, since defects during the assembly of the operator or incorrectly installed doors can result in injury.
- DoorHan is not liable, if the product is not correctly installed or is damaged during operation.
- Make sure, that there are no foreign bodies within the operating range of the electric operator before its start.
- You should not introduce changes, not stated in the given Manual, into the automatic system.
- You should remove the product package and dispose of it. You should not leave the packaging materials within the reach of children.
- You should not allow children to play in the door movement area during the operator operation. All remote control panels and also stationary control buttons must be absolutely inaccessible for possible use by children.
- It is allowed to drive in and to pass only when the doors do not move and the operator is switched off.
- The contents of the Manual could not serve as a basis for laying claims of any kind.
- The manufacturer reserves the right to introduce modifications into the structure and to improve it without prior notice.
- The Installation and configuration of the actuator must only be carried out by qualified specialists.
- After installing the drive, test force according to standards EN 12445 and EN 12453.



**IMPORTANT!** For safe and correct work of the operator it is necessary to install a mechanical stop to limit the door leaf motion.



**WARNING! RISK OF INJURY!**

Have a qualified technician lay the cables 230 V AC. The cables must be laid in protective corrugated tubes. In case of supply cable damage, use the suitable type of the cable.

**Cables needed for installation of Sectional-500PROCE/750PROCE/1000PROCE operator and accessories (if available)**

- Cable 2×0.5 mm<sup>2</sup> (photocell transmitter)
- Cabel 4×0.5 mm<sup>2</sup> (photocell receiver)
- Cable 3×1.5 mm<sup>2</sup> (power supply)
- The cables should be appropriately insulated

**3. OPERATOR UNIT**

**3.1. OVERALL DIMENSIONS**

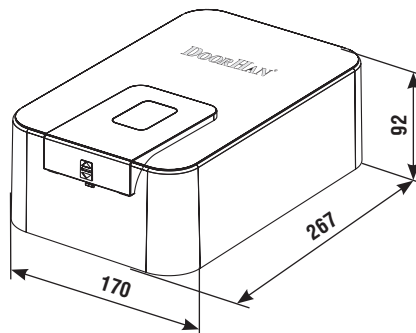

**3.2. DRIVE DEVICE**

1. Display cover
2. Housing cover
3. LED lamp
4. Display
5. Motor reducer
6. Control board
7. Housing
8. Plug terminals for connection of accessories
9. Reference point microswitch
10. Splined bushing

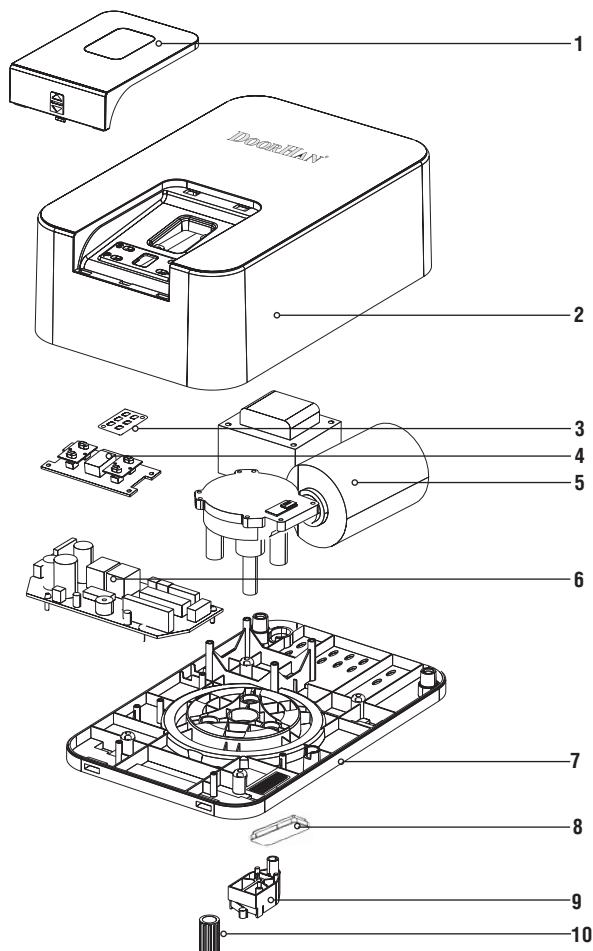

## 4. OPERATOR INSTALLATION

### 4.1. TOOLS

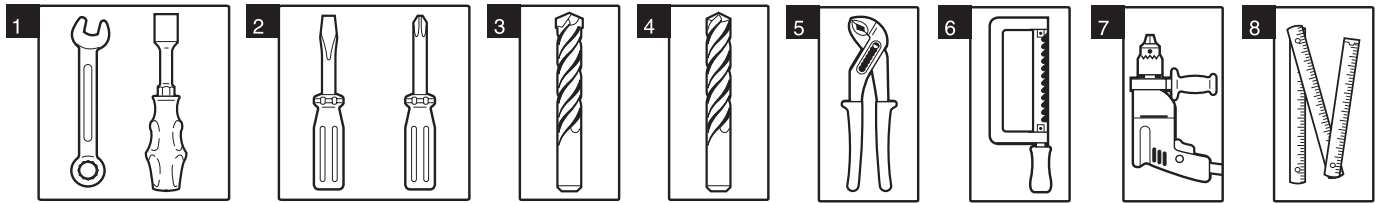

- |  |                               |                                |
|--|-------------------------------|--------------------------------|
| 1. Set of spanners                       | 4. Set of drills for concrete | 7. Electric drill              |
| 2. Set of slotted and cross screwdrivers | 5. Pliers                     | 8. Tape measure (folding rule) |
| 3. Set of drills for metal               | 6. Hacksaw for metal          |                                |

### 4.2. REQUIRMENTS TO DOOR INSTALLATION

- Prior to installation check if the door is properly balanced and moves smoothly when automatically operated.
- Make sure, that minimal clearance between the ceiling and the top point, when the door is moving, is not less than 45 mm (pic. 1).
- Check, that the door leaf top roller is in the horizontal part of the guide rail, when the door is completely closed (pic. 2).
- Mount the door control panel at a height not less than 1.5 m close to the door.

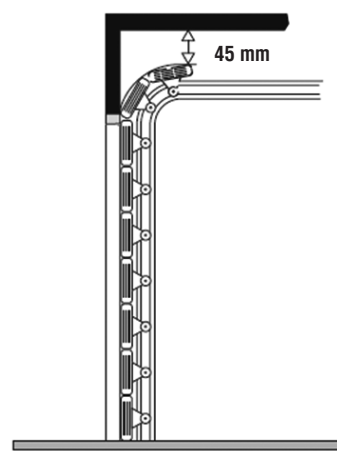

Pic. 1

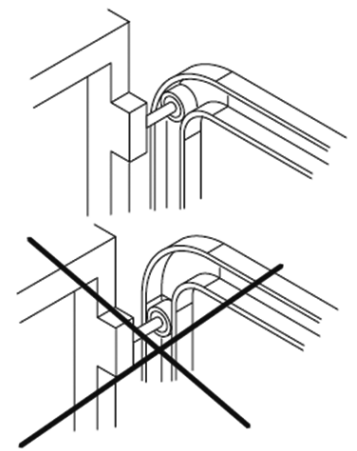

Pic. 2

### 4.3. CONNECTION OF OPERATOR AND GUIDE

1. Put the operator bushing (4) on the shaft (5).
2. Loosely tighten the drive mounting screws (7).
3. Insert the operator unit into the hole on the guide (3).
4. Fasten the operator with U-brackets (2) and tapping screws (1).

- |   |
|---|
| 1. U-bracket                                    |
| 2. Guide  |
| 3. Bushing                                      |
| 4. Plug terminals for connection of accessories |
| 5. Micro switch reference point                 |
| 6. Motor shaft                                  |
| 7. The drive mounting screws                    |

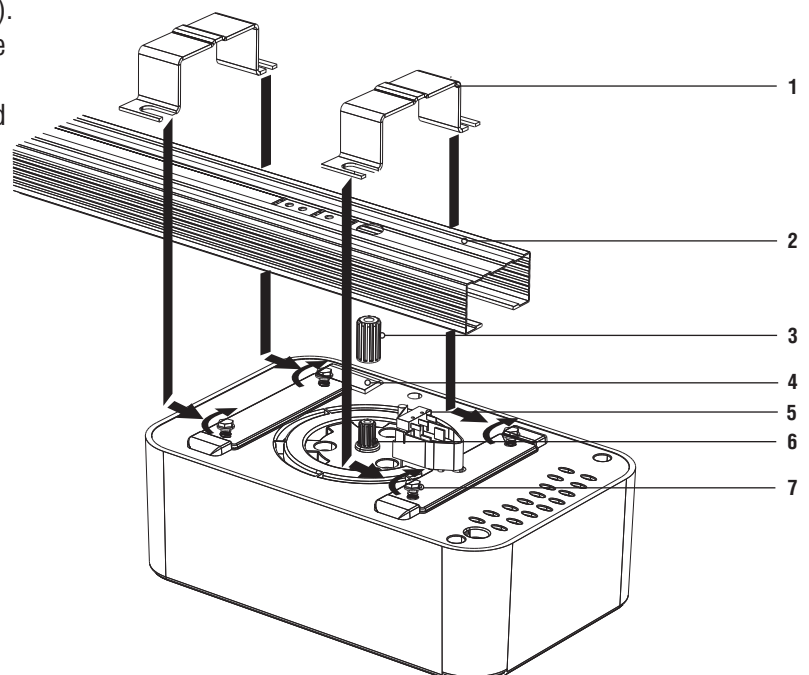

**4.4. TRACK INSTALLATION**

The operator suspension height is determined by the maximum lift of upper edge of the door leaf. After preliminary assembly (see p. 4.3) you can start to install the track:

1. If it is required to shorten a guide, it is necessary to fulfill operations, described in Appendix 1.
2. You should mark a vertical line, corresponding to the horizontal door centre (fig. 5).
3. You should place a lintel mounting bracket (1) in such a way that the distance from upper edge of the open door leaf to lower edge of the track amounted to minimum 10 mm (fig. 5.2) and fix it to the lintel using self-tapping screws (2) (fig. 5.1).
4. You should fasten the track (3) and the lintel mounting bracket by means of a track fixation bolt (4) (fig. 5.3).
5. You should install a U-shaped bracket (5) on the track approximately at a distance  $2/3 L$  and attach it to the ceiling (fig. 5.4).
6. You should install track mounting brackets (6) on the track approximately at a distance  $1/3 L$  and attach them to the ceiling (fig. 5.5).
7. You should install a rod-to-leaf mounting bracket (7) in the middle of the upper aluminium profile of the door leaf and fix it using self-tapping screws (8) (fig. 5.6).
8. You should attach a cranked rod (9) to the rod mounting bracket and fix it by means of a pin axle (10) (fig. 5.7). It is allowed not to mount the cranked rod, if  $\alpha$  angle is observed.

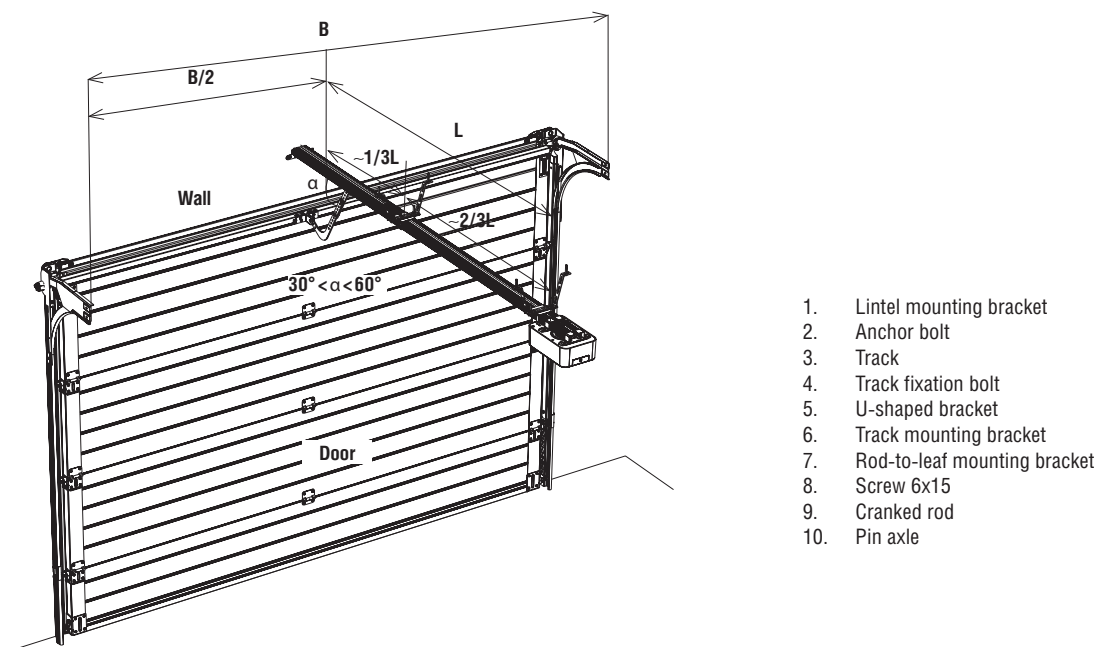

Pic. 5

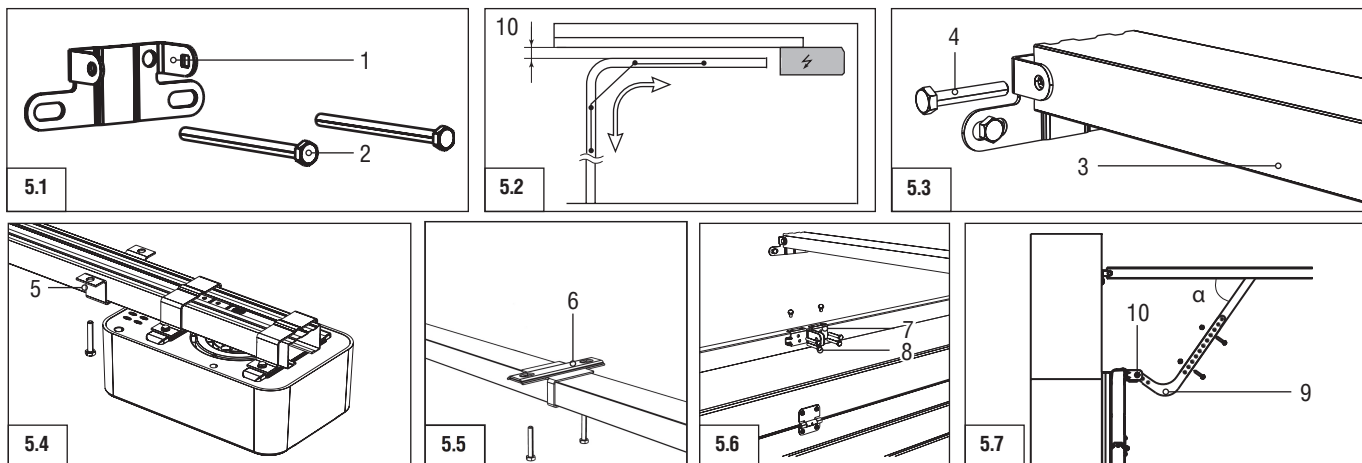

## 5. ELECTRICAL CONNECTIONS

### 5.1 Control block specifications

Parameters	Units
Power supply	180-240 V/50-60 Hz
Power supply of accessories	24 V DC
Maximal current of accessories	200 mA
Working temperature range	-20...+55 °C
Radio control frequency	433,92 MHz
Operating logics	Automatic/Semi-automatic
Connectors	Open button/Safety devices
Lamp turn-on time	3 min
Fuse type	Quick cutoff fuse, 230 V, 2.5 A

### 5.2 Control block wiring diagram



**WARNING!** The cable wires must be protected from contact with any rough or sharp parts. All connections shall be made only when power is off.

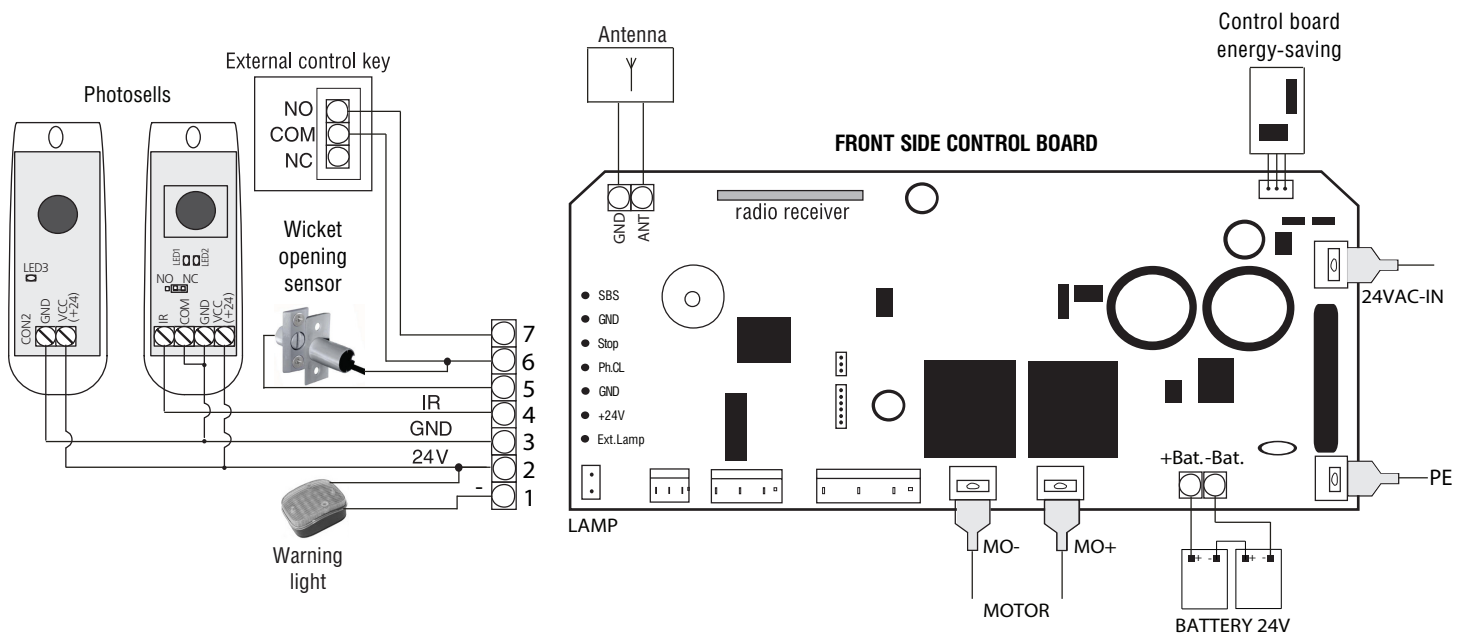

For good convenience of connecting accessories the opener has removable terminal, which is located under cap (look at the picture), it allows to perform all necessary connections without opener disassembling.

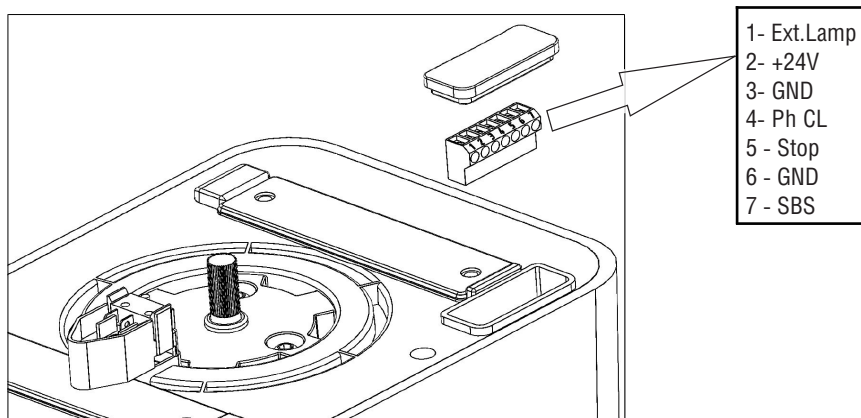



**5.3 Operator programming**

**1. OPERATOR CONTROL KEYS**

1. Radio code record button — “R”
2. Display
3. Setting selection buttons — “+”, “-”
4. Programming button — “P”

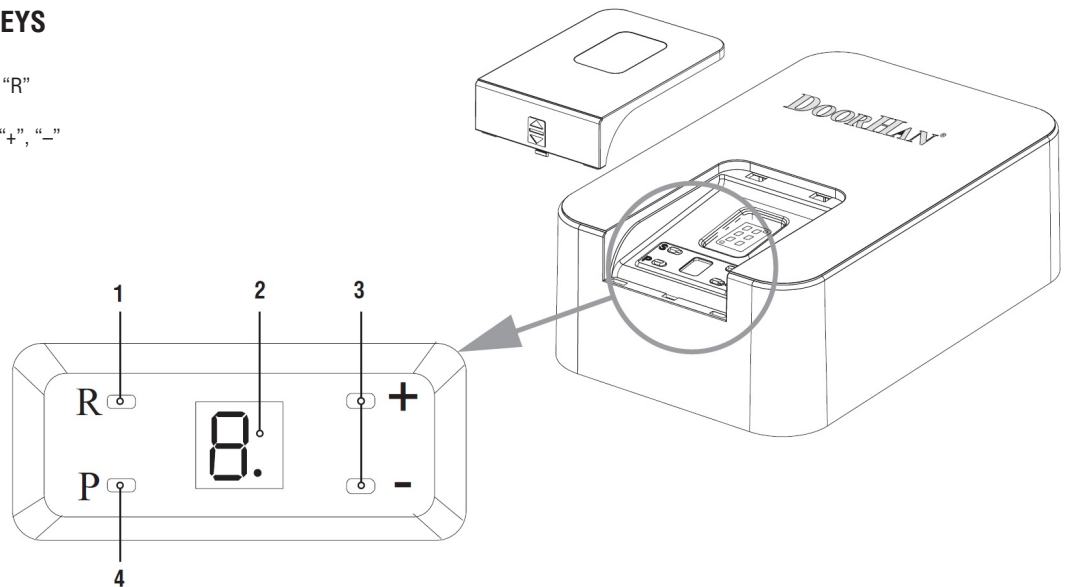

**PREPARATION**

Block the carriage.

Turn on power, the indicator of the operator will light, sound signal will be heard.

If programming has not been completed, the settings will not be stored. If there is a mistake in one of the settings, you can turn off power and reprogram.

**5.4 BASE PROGRAMMING**

**Base programming table**

Menu item	Function description	By default
1	Door upper position	-
2	Door lower position	-
3	Automatic adjustment of effort	<b>3</b>
4	Partial door opening button number selection (venting mode)	<b>0</b>
5	Absolute cycle counter	<b>0</b>
6	Remote control recording function	<b>y</b>
7	Open door auto-close function “0” - no automatic closing; “1” -30 sec. pause; “1” - 60 sec. pause; ...“8” - 240 sec. pause	<b>0</b>
8	Reset to factory settings	<b>r</b>
9	Software version	<b>1.0</b>

**UPPER DOOR POSITION**

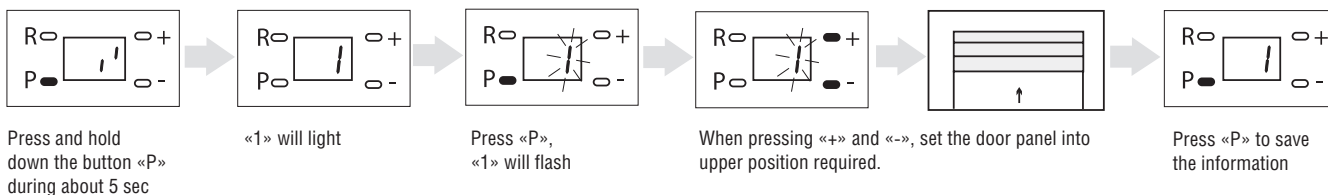

The setting will be stored only when you program the UPPER door position. The upper position shall be programmed before setting the lower door position.

**LOW DOOR POSITION**

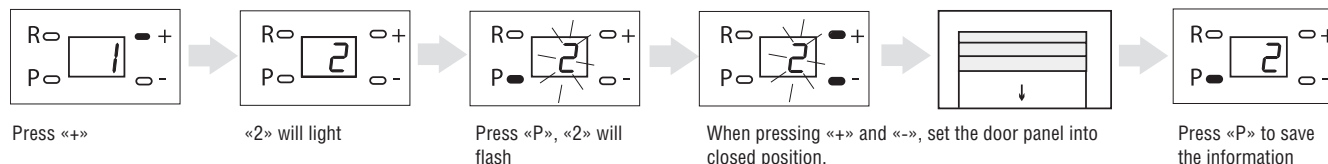

The setting will be stored only when you program the LOW door position.

**AUTOMATIC FORCE SETUP**

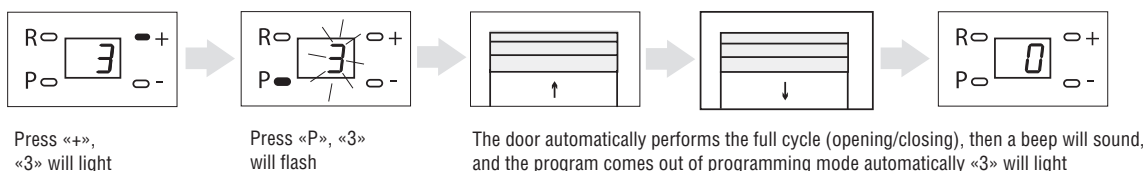

**After finishing the automatic force setup, a beep will sound, and the program comes out of programming mode automatically.**

After performing these setups, the programming can be finished; all other parameters have factory settings.

**PARTIAL DOOR OPENING BUTTON NUMBER SELECTION (VENTING MODE)**

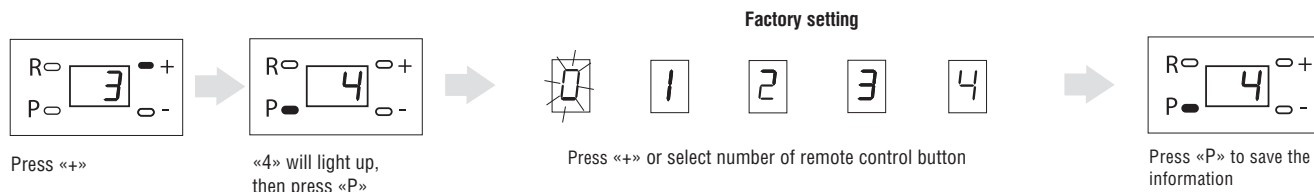

**ABSOLUTE CYCLE COUNTER**

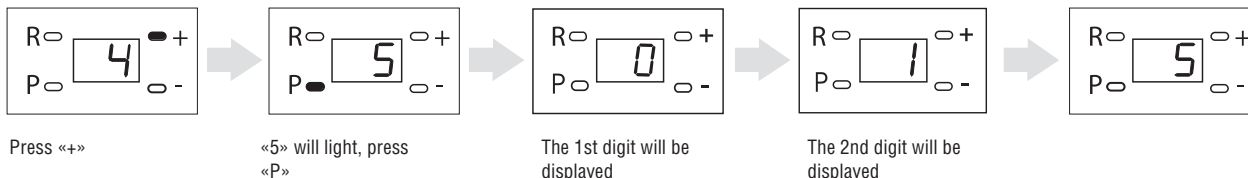

When entering the 5th point of menu, two digits will be displayed sequentially. After having displayed the digits, the program returns to main menu.

The first digit – tens, the second digit – units.

The value received is multiplied by 1000 to receive information on amount of cycles driven by the operator.

**DISABLE REMOTE RECORDING REMOTES**

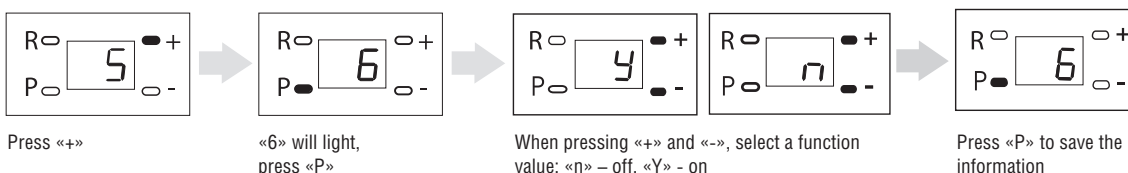

**AUTOMATIC CLOSING**

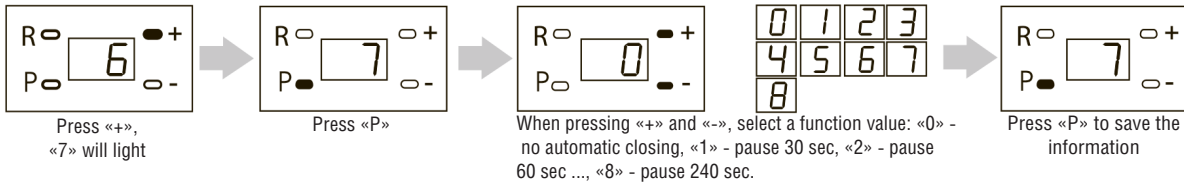

**RESET TO FACTORY SETTINGS**

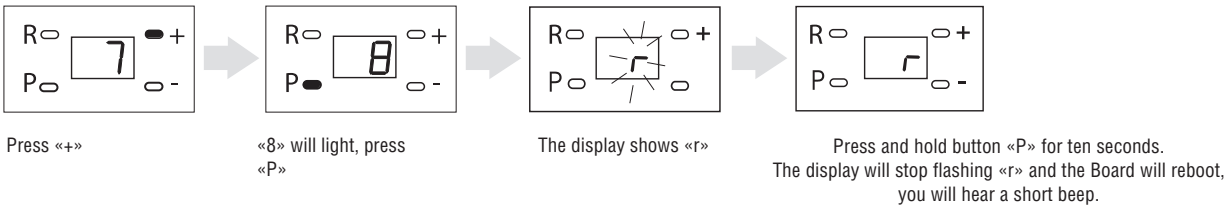

After above settings, all settings will be reset TO the FACTORY default (the stress limit is "3"; remote entry remotes-Y(incl.); auto close-"0"(off)).

**CHECK SOFTWARE VERSION**

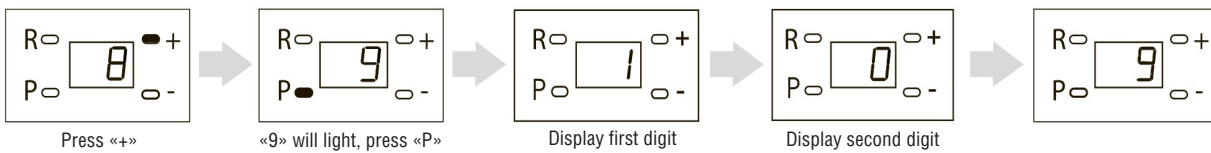

At the entrance to the 9th menu item, sequentially displays two numbers. After displaying the numbers of the who programme-rotates to the main menu.

**COMPLETING THE PROGRAMMING**

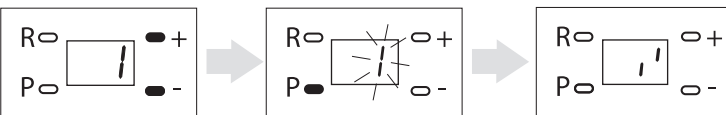

To exit programming mode, press "R".Programming completed.

NOTE: You can go from any point of programming.

**! WARNING!** The output of the sub menu when clicking on the "R" leads to not save custom setting.

**5.5 ADVANCED PROGRAMMING**

To enter the advanced programming, press and hold "P" button for 15 seconds, display will show "1."

**Advanced programming table**

Menu item	Function description	By default
1	Carriage reverse at closed door position "Y" - on. "n" - off.	n
2	Selection of safety devices type (photocells): "0" - external. "1" - built-in.	0
3	Selection of the door raising height at "partial opening" (venting): "0" - 200mm. "1" - 1000mm.	0
4	Function prevent control commands during the movement of gate on opening: "Y" - on. "n" - off.	n

**REVERSE AT THE LOWER END POSITION OF THE DOOR (FUNCTION «EASY UNLOCK»)**

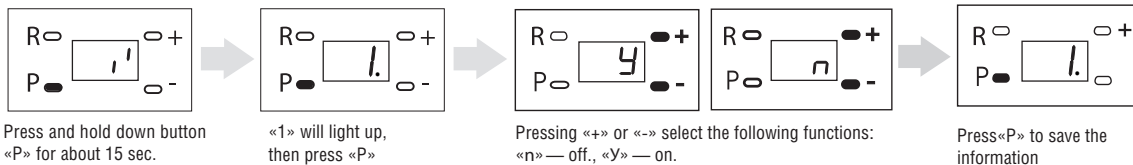

**SELECTION OF SAFETY DEVICES TYPE**

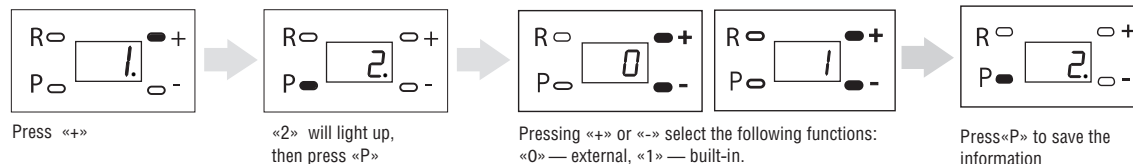

**ADJUSTING OF THE DOOR RAISING HEIGHT - «PARTIAL OPENING» FUNCTION (VENTING)**

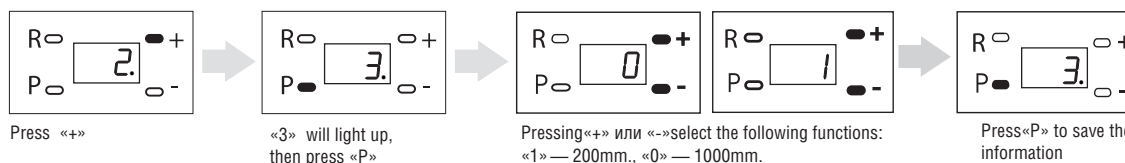

To control the «partial opening» function, in the fourth menu item (see base programming) select the remote control number button, which will subsequently enable this function. By pressing the selected remote control button the door will open to the set position (see p. 3 of Advanced Programming).

**Note:**

-The selected button must be recorded into receiver memory.

**FUNCTION PREVENT CONTROL COMMANDS DURING THE MOVEMENT OF GATE ON OPENING**

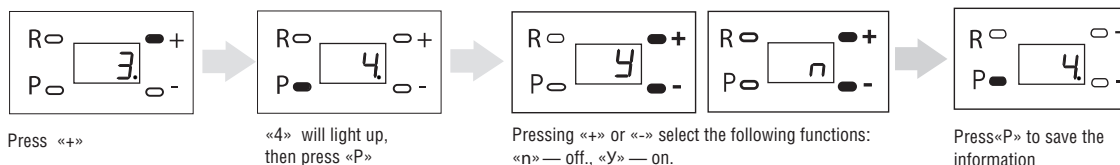

**POWER SAVING MODE**

To save electric energy consumption there is provided power saving mode with the control board.

If there are no commands within three minutes, the program disables display screen, the unit is changed over to power saving mode. Pressing control buttons on the operator or sending commands from the control panel in power saving mode will switch the control board into the operating mode and perform the issued command.

**Note:**

- If the operator is used with a backup battery and its charge is less than 100%, the operator will not change over to power saving mode until the backup battery is fully charged.
- If the backup battery is deeply discharged, the door can stop during movement.

**BACKUP BATTERY CHARGE DISPLAY**

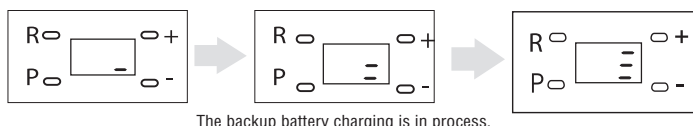

**5.6 REMOTE CONTROLS PROGRAMMING**

**REMOVAL OF ALL REMOTE CONTROLS FROM THE RECEIVER MEMORY**

After the power is ON, press and hold down button “R” for about 20 seconds (during this time you will hear 2 short beeps), then a long sound signal will be generated, and the program will switch to the operating mode.

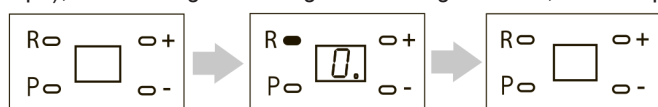

### RECORDING OF DOORHAN REMOTE CONTROL INTO RECEIVER

1. Press and hold the “R” button, until the indicator “0” appears on the display. Release the button.
  2. Select the button on the remote control, using which you will later operate the unit, and press it twice. A short sound signal will be generated, meaning successful recording of the panel into the receiver.
  3. Repeat the code recording procedure for each panel to record several panels.
- Thus, it is possible to record up to 60 panels into the receiver memory.

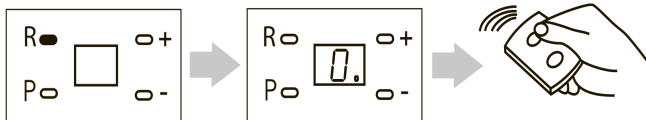

#### Note:

- 3 long sound signals will be generated in case of the receiver memory overflow.
- In the absence of control commands the mode of panel recording is switched off automatically within 10 seconds.
- The programmed data is stored in the memory when the control unit is disconnected from the network.

### REMOVAL OF SINGLE REMOTE CONTROL FROM THE RECEIVER MEMORY

To remove one particular remote control, you must press and hold down the button «R», then release it after the second beep, «0». indicator on the display will start flashing. Then double press the recorded button of remote control you want for delete from the receiver memory. 3 short beeps will sound, indicating the remote control is successfully deleted from the receiver memory. To delete several remote controls repeat the deletion step for each new remote.

#### Note:

- If there are no commands from the panel, the single remote control removal mode will be automatically quit within 5 seconds.

### REMOTE PROGRAMMING OF CONTROLS

Steps 1 - 4 should be performed in five second interval being in close proximity to actuator:

1. Press and hold down button «2» of the programmed remote control panel.
2. Press and hold down button “1” without releasing the pressed button “2”.
3. Release the pressed buttons.
4. Press the programmed button of the remote control.
5. Select the button on the new remote control, using which you will later operate the unit, and press it twice. A short beep will sound.

**Note:** All four control buttons can be programmed for the actuator.

### MARKING REMOTE CONTROL BUTTONS DOORHAN



## 6. MANUAL OPENING

### OPENING BY MEANS OF INTEGRATED CARRIAGE RELEASING DEVICE

Manual disengagement of automatic system

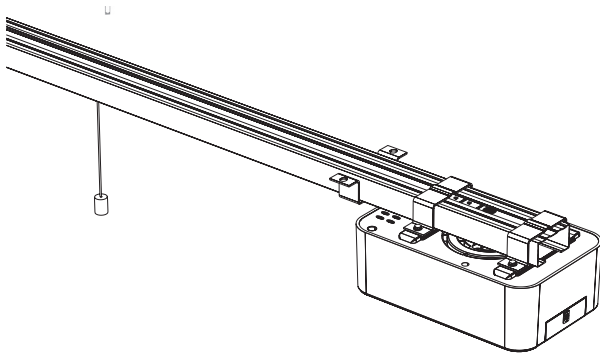

Figure 7

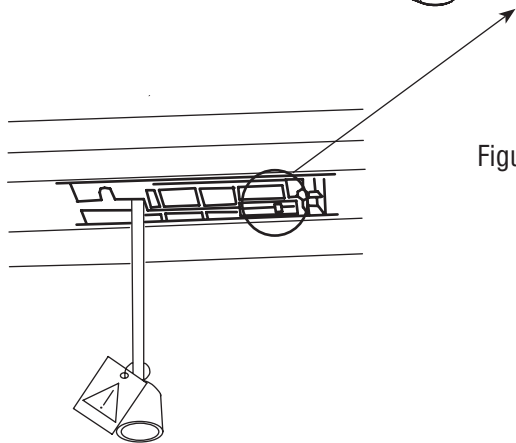
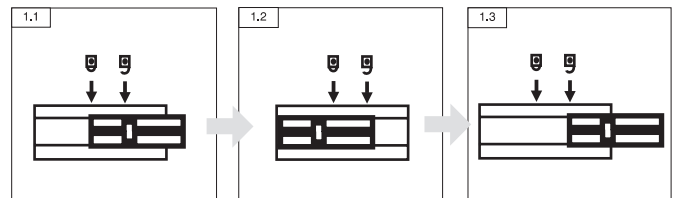

Figure 8

Manual door control



Locked position

Pull the cord down and move the rod to the position shown in the Figure

Unlocked position

Automatic door control

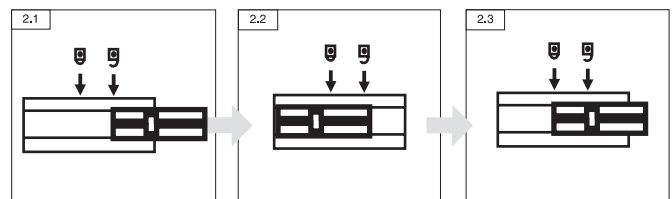

Unlocked position

Pull the cord down and move the rod to the position shown in the Figure

Locked position



#### In the event of main power failure

In the event of main power failure, the operator can be switched to manual control. To do this, pull down the releasing device cord. The carriage should withdraw from the engagement, and after that the door can be operated manually (Fig. 7).



#### When main power is restored

When main power is restored, the operator is to be set to automatic control. To do this, move the carriage into the locked position by pulling the releasing device cord to yourself (Fig. 8). After this, trigger a signal from the remote control or control button, wait till the carriage clutches with chain (belt).



**IMPORTANT!** When the carriage is blocked, the door will move automatically only after the carriage meshes with the chain support.

## 7. MAINTENANCE

- The Sectional-500PROCE/750PROCE/1000PROCE automatic system does not require any special servicing.
- Repairs may be carried out only by a qualified technician trained and certified at an authorized DoorHan centre.
- Be sure that after completion of installation the installer has shown the user how to release the door in case of emergency and has given instructions on proper operation and maintenance of the automated system.
- When carrying out maintenance, it is recommended to use DoorHan original spare parts.
- Carry out maintenance of the automatic system at least every six months.
- Regularly check if the door is properly balanced and moves smoothly when automatically operated.
- Regularly check if the safety devices are in good working condition.
- In case of power failure you may need to restore operator's settings, In case of a power outage, you may need to restore the settings of the drive. To do this, make a complete cycle of opening \ closing the door.
- In case of power failure the door will stop. As soon as power supply is restored you can control the operator as usual.
- After expiration of life time, the item shall be delivered in a specialized disposal point!
- If you have lost this Manual, you may request for the duplicate copy to the following address: Kralovský VRCH 2018, Kadan, 43201, Czech Republic, or by email: europe@doorhan.com.
- The producer (DoorHan) does not supervise the installation of operators, or carry out their maintenance, thus DoorHan cannot be held liable for safety of installation, operation and maintenance of the equipment.

## 8. TROUBLESHOOTING

Symptom	Possible reason	Possible solution
Operator does not run	1. No power 2. Fuse is broken	1. Turn on the power 2. Replace the fuse
Remote control does not run	Remote control is not entered. Remote control battery is discharged	Re-entry the remote control Replace the battery
Remote control actuation distance is too small	Remote control battery is discharged	Replace the battery
Chain moves and door does not move	Carriage is disengaged and is not meshed with chain support	Engage the carriage. Connect it to chain support
Door does not reach end positions or does not work	Programming error	Reprogram the door
Noise when operator runs	Chain is not properly lubricated	Lubricate the chain
Chain makes noise and rubs against the guide	Chain has stretched	Tighten the chain using chain tension screw, lubricate the gear wheel
The doors have suddenly stopped, "F" indicator is on	The doors ran into obstacle, or mechanics is blocked	Check the door mechanics, remove the obstacle
The door suddenly stopped, indicator shows «A»	Safety devices activated	Free the doorway from obstacle / Check safety devices operation
The door suddenly stopped, indicator shows «C»	Insufficient supply voltage	Make sure the power supply voltage is in accordance with the stated characteristics

**Note:**

-In the process of door movement indicator shows «L», which means actuation of the door synchronization micro-switch (reference point micro switch). This indicator does not mean the operator failure.

## APPENDIX

## GUIDE CUTTING

1. Unpack a guide and inspect it. Make sure that the guide is not damaged. If you have found any damages, please contact the supplier.
2. Disassemble a chain tensioner mechanism, pos. 1 (fig. 1).

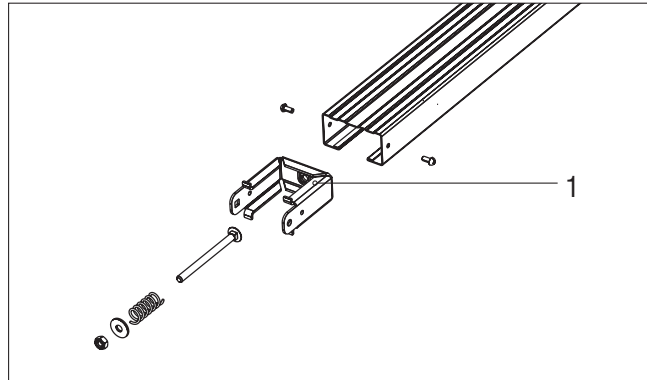

Fig. 1

3. Unfasten screws of a sprocket holder, pos. 2 (fig. 2).

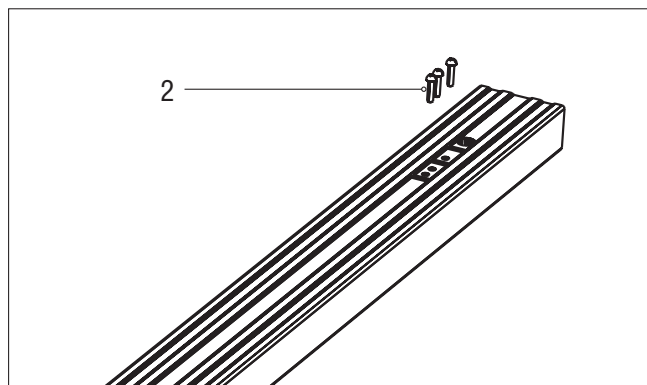

Fig. 2

4. Remove a chain with a carriage mechanism, pos. 3 (fig. 3).

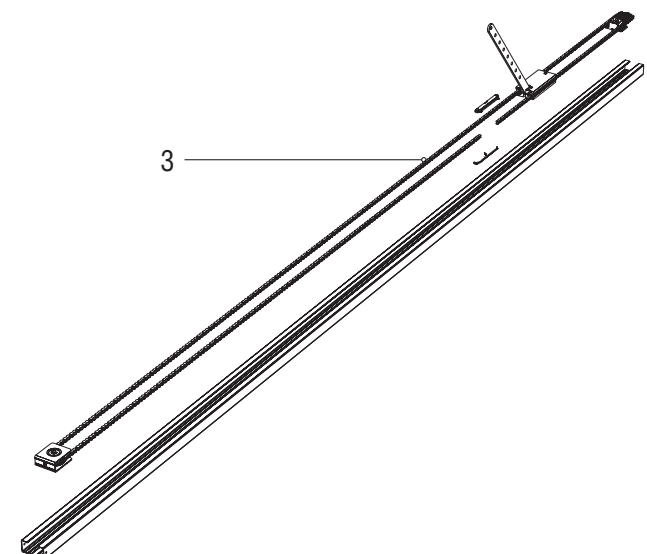

Fig. 3



5. Disassemble a support, pos. 4, into two parts (fig. 4).

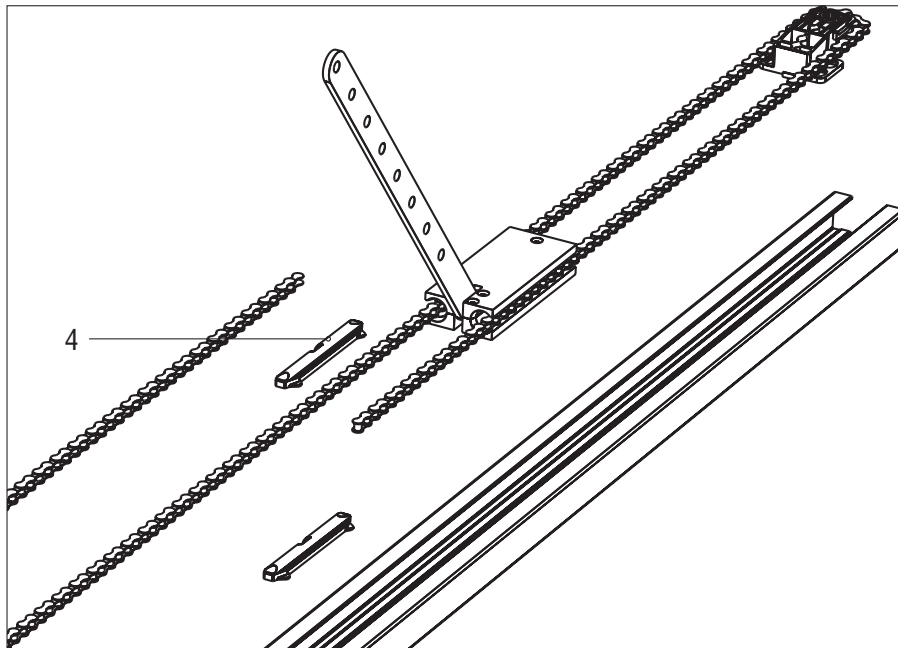

Fig. 4

6. Cut the guide and shorten the chain to the required dimensions (fig. 5).

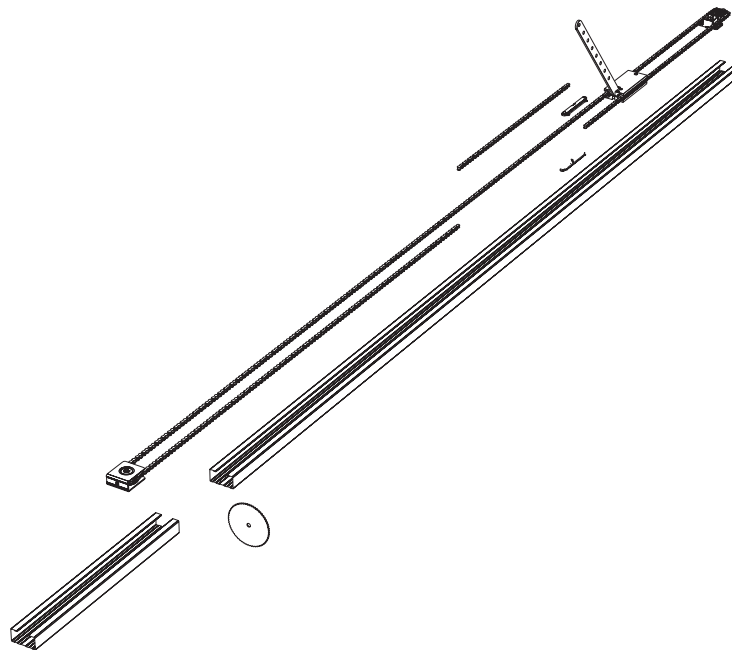

Fig. 5

7. After cutting assemble the guide in reverse order.





# ***DOORHAN***<sup>®</sup>

We very much appreciate that you have chosen the product manufactured by our company and believe that you will be satisfied with its quality.

For information on purchasing, distribution and servicing  
contact DoorHan central office at:  
Kralovsky VRCH 2018, Kadan,  
43201, Czech Republic  
Telephone: +420 474 319 111  
E-mail: [europa@doorhan.com](mailto:europa@doorhan.com)  
[www.doorhan.cz](http://www.doorhan.cz)